

Spare parts list

Handheld pneumatic breakers

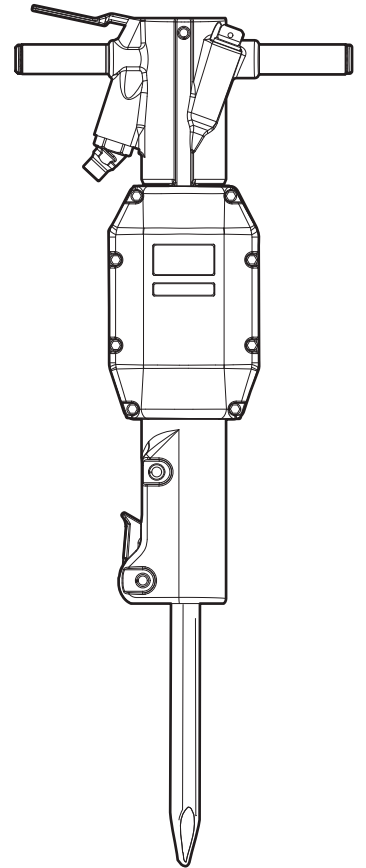

Contents

Spare parts list	4
TEX P60 hexagon 28 x 160, TEX P60 hexagon 32 x 160	4
TEX P60 S hexagon 28 x 160, TEX P60 S hexagon 32 x 160	6
Working tools	8
ISO standard hexagon 28 x 160 mm (1 1/8" x 6 1/4")	8
ISO standard hexagon 32 x 160 mm (1 1/4" x 6 1/4")	9
US standard hexagon 1 1/8" x 6" (28 x 152 mm)	9
US standard hexagon 1 1/4" x 6" (32 x 152 mm)	10
Accessories	11
Claw couplings	11
Breaker and hammer AIR-OIL	12
Shank gauge	12

Spare parts list

TEX P60 hexagon 28 x 160, TEX P60 hexagon 32 x 160

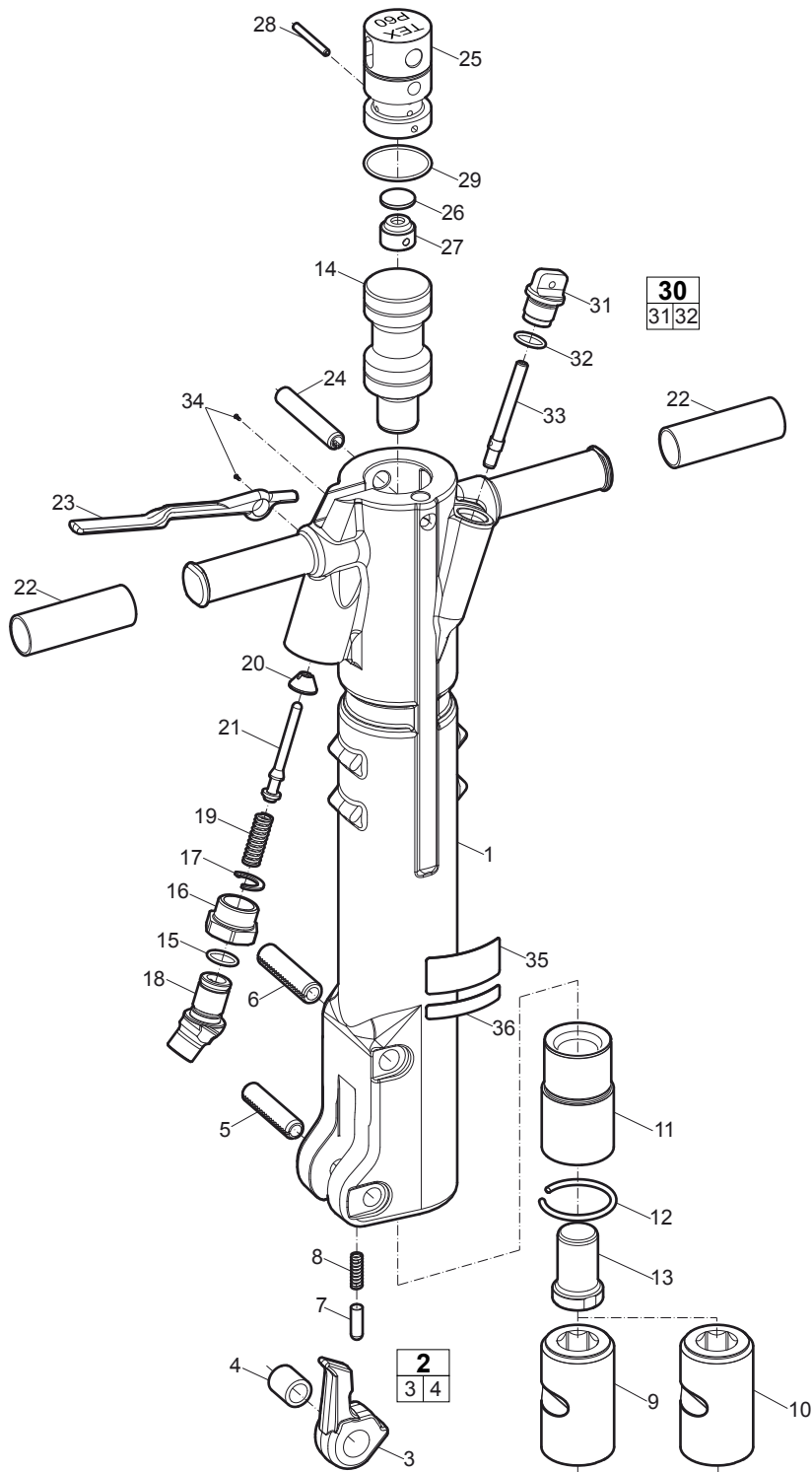

No.	Description	Remark	Quantity	Part number
1	Main body		1	3310 1269 00
2(3-4)	Tool retainer, complete		1	3310 0889 80
3	Tool retainer		1	-
4	Bushing		1	3310 0892 00
5	Spring pin	Ø18 x 80 mm	1	0108 1691 06
6	Spring pin	Ø20 x 80 mm	1	0108 1691 54
7	Plunger		1	3310 0893 00
8	Spring		1	3310 0894 00
9	Tool bushing	hexagon 28 x 160 mm, 28 x 152 mm	1	3310 1263 01
10	Tool bushing	hexagon 32 x 160 mm, 32 x 152 mm	1	3310 1263 00
11	Intermediate part		1	3310 1264 00
12	Lock ring		1	3310 1053 00
13	Anvil		1	3310 1265 00
14	Piston		1	3310 1280 00
15	O-ring	Ø22.2 x 3.0 mm	1	0663 2126 00
16	Swivel nut		1	3310 1044 00
17	Lock washer		1	3310 1059 00
18	Swivel	¾"	1	3310 1257 01
19	Spring		1	3310 1216 00
20	Inlet valve		1	3310 1211 00
21	Valve stem		1	3310 1258 00
22	Sleeve		2	3310 1335 00
23	Trigger		1	3310 1251 00
24	Spring pin	Ø16 x 95 mm	1	0108 1691 55
25	Valve housing		1	3310 1256 00
26	Main valve		1	3310 1173 00
27	Valve cover		1	3310 1245 00
28	Spring pin	Ø6 x 55 mm	1	0108 1335 00
29	O-ring	Ø49.5 x 3.0 mm	1	0663 6134 00
30(31-32)	Oil plug, complete		1	3310 1538 80
31	Oil plug		1	-
32	O-ring	Ø22.2 x 3.0 mm	1	0663 2126 00
33	Dosing feeder		1	3310 1260 00
34	Screw		2	0244 4144 00
35	Label	Atlas Copco	1	0690 1101 03
36	Label	P60	1	3310 1290 00

TEX P60 S hexagon 28 x 160, TEX P60 S hexagon 32 x 160

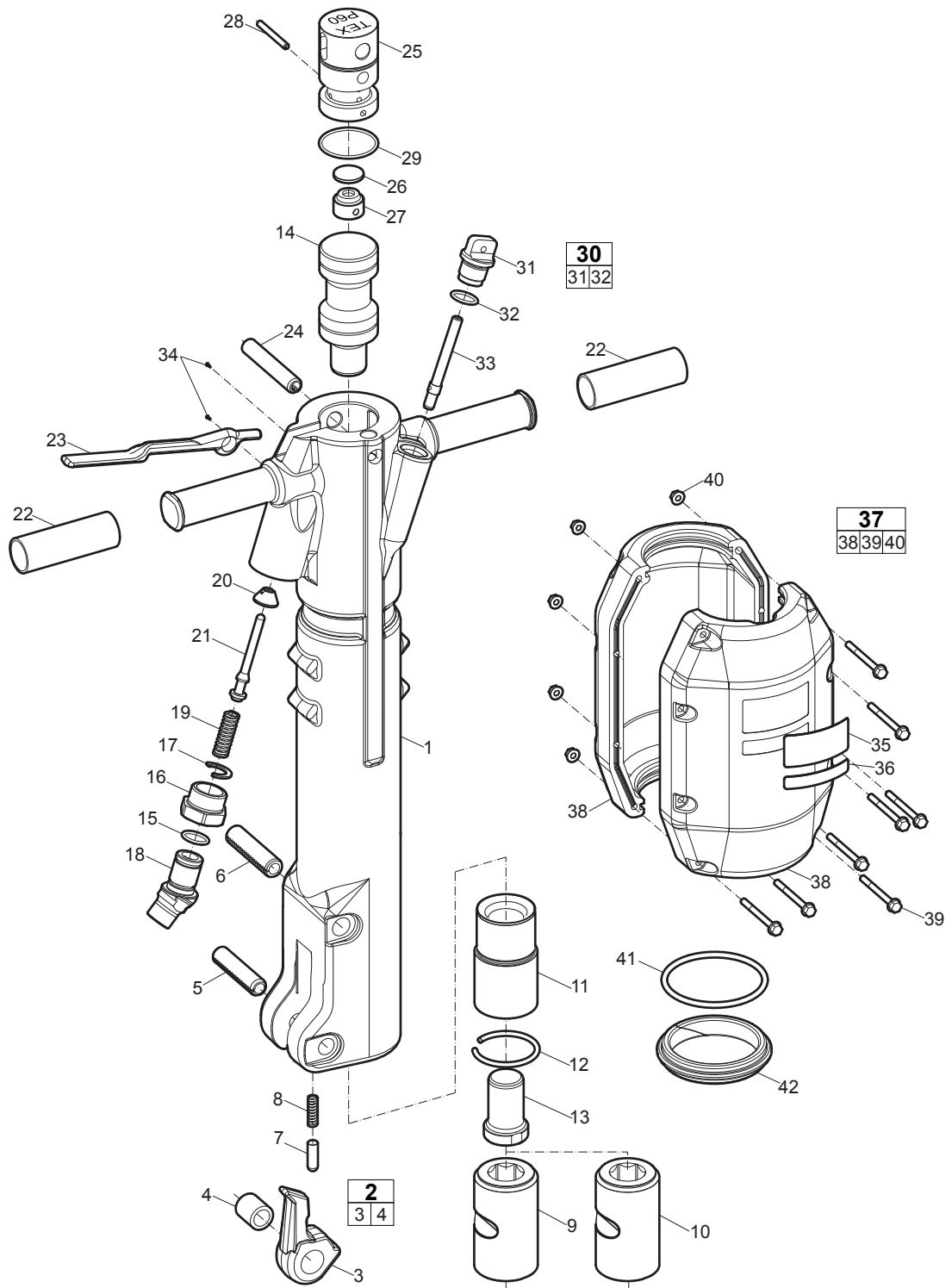

No.	Description	Remark	Quantity	Part number
1	Main body		1	3310 1269 00
2(3-4)	Tool retainer, complete		1	3310 0889 80
3	Tool retainer		1	-
4	Bushing		1	3310 0892 00
5	Spring pin	Ø18 x 80 mm	1	0108 1691 06
6	Spring pin	Ø20 x 80 mm	1	0108 1691 54
7	Plunger		1	3310 0893 00
8	Spring		1	3310 0894 00
9	Tool bushing	hexagon 28 x 160 mm, 28 x 152 mm	1	3310 1263 01
10	Tool bushing	hexagon 32 x 160 mm, 32 x 152 mm	1	3310 1263 00
11	Intermediate part		1	3310 1264 00
12	Lock ring		1	3310 1053 00
13	Anvil		1	3310 1265 00
14	Piston		1	3310 1280 00
15	O-ring	Ø22.2 x 3.0 mm	1	0663 2126 00
16	Swivel nut		1	3310 1044 00
17	Lock washer		1	3310 1059 00
18	Swivel	¾"	1	3310 1257 01
19	Spring		1	3310 1216 00
20	Inlet valve		1	3310 1211 00
21	Valve stem		1	3310 1258 00
22	Sleeve		2	3310 1335 00
23	Trigger		1	3310 1251 00
24	Spring pin	Ø16 x 95 mm	1	0108 1691 55
25	Valve housing		1	3310 1256 00
26	Main valve		1	3310 1173 00
27	Valve cover		1	3310 1245 00
28	Spring pin	Ø6 x 55 mm	1	0108 1335 00
29	O-ring	Ø49.5 x 3.0 mm	1	0663 6134 00
30(31-32)	Oil plug, complete		1	3310 1538 80
31	Oil plug		1	-
32	O-ring	Ø22.2 x 3.0 mm	1	0663 2126 00
33	Dosing feeder		1	3310 1260 00
34	Screw		2	0244 4144 00
35	Label	Atlas Copco	1	0690 1356 00
36	Label	P60 S	1	3310 1289 00
37(38-40)	Silencer, complete		1	3310 1261 80
38	Silencer		1	-
39	Flange screw	M6 x 65 mm	8	0147 3000 32
40	Flange nut	M6 Triloc	8	9232 0207 50
41	O-ring	Ø94.1 x 5.7	1	0663 2146 00
42	Rubber bushing		1	3310 1262 00

Working tools

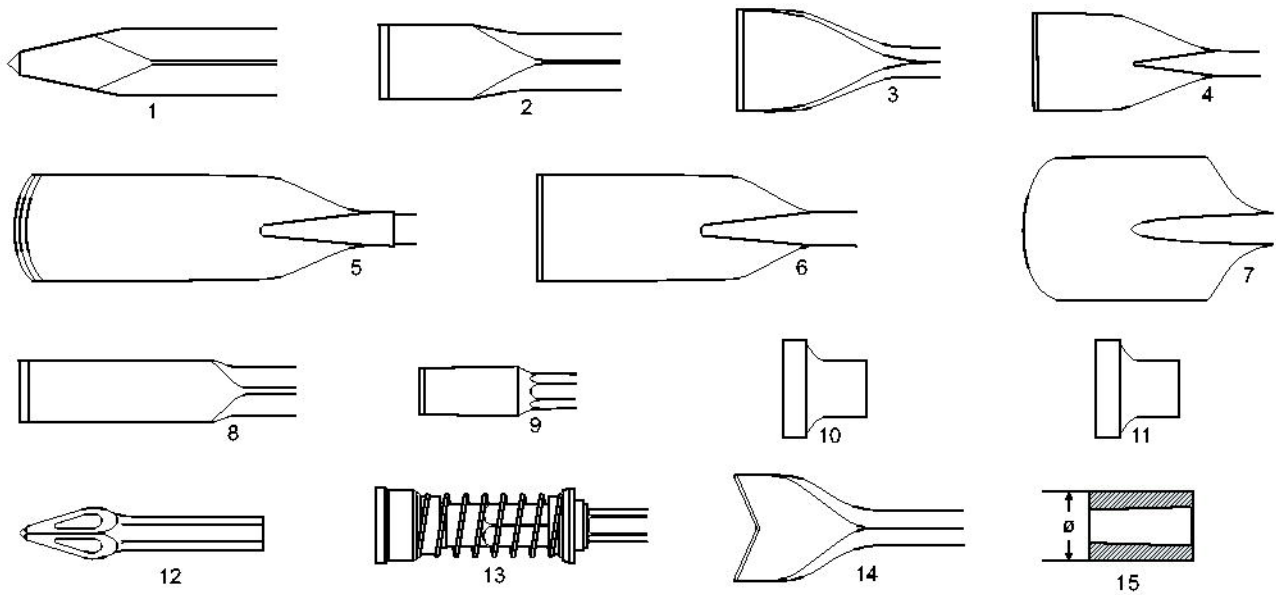

ISO standard hexagon 28 x 160 mm (1 1/8" x 6 1/4")

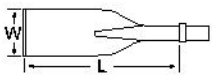

No.	Description	W (mm)	L (mm)	Part number
1	Moil point	-	380	3083 3271 00
		-	450	3083 3272 00
		-	1000	3083 3273 00
2	Narrow chisel	32	380	3083 3274 00
		32	450	3083 3275 00
		32	1000	3083 3276 00
3	Wide chisel	75	380	3083 3277 00
4	Asphalt cutter	115	300	3083 3278 00
5	Digging chisel	75	380	3083 3279 00
6	Digging spade	125	380	3083 3280 00
7	Clay spade	140	380	3083 3281 00
8	Wedge chisel	40	400	3083 3282 00
9	Shaft for tamping pad	-	230	3083 3283 01
10	Tamping pad, round	180	-	3083 3301 00
11	Tamping pad, square	150	-	3083 3302 00
		200	-	3083 3197 00
12	Heavy duty-buster	-	380	3083 3315 00
14	Tie tamper	100	400	3083 3319 00
15	Driver blank	80	-	9245 2827 10

ISO standard hexagon 32 x 160 mm (1¼" x 6¼")

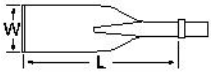

No.	Description	W (mm)	L (mm)	Part number
1	Moil point	-	380	3083 3205 00
		-	450	3083 3206 00
		-	1000	3083 3207 00
2	Narrow chisel	35	380	3083 3208 00
		35	450	3083 3209 00
		35	1000	3083 3210 00
3	Wide chisel	75	380	3083 3211 00
4	Asphalt cutter	115	300	3083 3212 00
5	Digging chisel	75	380	3083 3213 00
6	Digging spade	125	380	3083 3214 00
7	Clay spade	140	380	3083 3215 00
8	Wedge chisel	40	400	3083 3216 00
9	Shaft for tamping pad	-	235	3083 3218 01
10	Tamping pad, round	180	-	3083 3301 00
11	Tamping pad, square	150	-	3083 3302 00
		200	-	3083 3197 00
13	Spiking tool	-	195	9245 2826 81
14	Tie tamper	100	400	3083 3217 00
		100	580	3083 3217 10
15	Driver blank	80	-	9245 2827 10

US standard hexagon 1⅛" x 6" (28 x 152 mm)

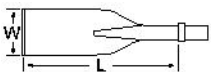

No.	Description	W (in.)	L (in.)	Part number
1	Moil point	-	14	3083 3267 00
		-	18	3083 4015 10
		-	36	3083 4015 20
2	Narrow chisel	1¼	14	3083 3268 00
		1¼	18	3083 4016 10
		1¼	36	3083 4016 20
3	Wide chisel	3	15	3083 3289 00
		3	18	3083 4017 00
4	Asphalt cutter	5	13	3083 3290 00
		4½	11	3083 4019 00
5	Digging chisel	3	15	3083 3291 00
6	Digging spade	5	15	3083 3292 00
7	Clay spade	5½	15	3083 3293 00
8	Wedge chisel	2	16	3083 3294 00
9	Shaft for tamping pad	-	9	3083 3269 00
10	Tamping pad, round	7	-	3083 3301 00
11	Tamping pad, square	6	-	3083 3302 00
		8	-	3083 3197 00
15	Driver blank	3	-	9245 2827 10

US standard hexagon 1¼" x 6" (32 x 152 mm)

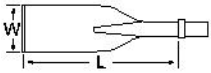

No.	Description	W (in.)	L (in.)	Part number
1	Moil point	-	14	3083 3285 00
		-	18	3083 4000 10
		-	36	3083 4000 20
2	Narrow chisel	1⅜	14	3083 3286 00
		1⅝	18	3083 4001 10
		1⅞	24	3083 4001 20
3	Wide chisel	3	15	3083 3295 00
		3	18	3083 4002 00
4	Asphalt cutter	5	13	3083 3296 00
		4½	12	3083 4004 00
5	Digging chisel	3	15	3083 3297 00
6	Digging spade	5	15	3083 3298 00
7	Clay spade	5½	15	3083 3299 00
8	Wedge chisel	2	16	3083 3300 00
9	Shaft for tamping pad	-	9	3083 3287 00
10	Tamping pad, round	7	-	3083 3301 00
11	Tamping pad, square	6	-	3083 3302 00
		8	-	3083 3197 00
14	Tie tamper	4	16	3083 3314 00
15	Driver blank	3	-	9245 2827 10

Accessories

Claw couplings

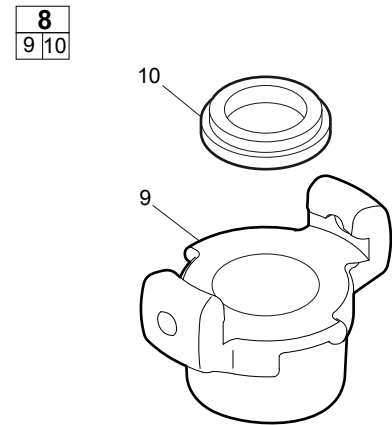
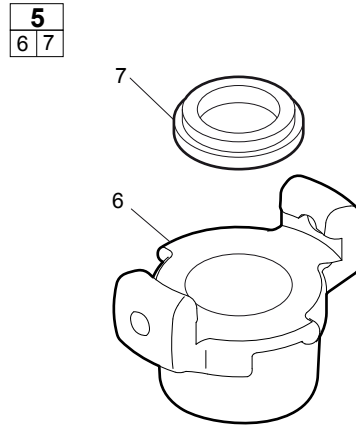
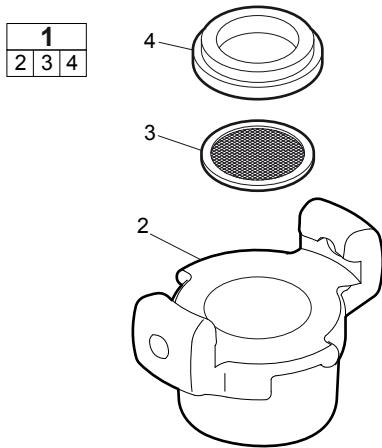

No.	Description	Remark	Quantity	Part number
1(2-4)	Claw coupling with strainer, complete	Standard G $\frac{3}{4}$ "	1	9000 0306 01
2	Claw coupling		1	-
3	Strainer		1	9000 0000 10
4	Seal		1	9000 0000 00
5(6-7)	Claw coupling, complete	Standard G $\frac{3}{4}$ "	1	9000 0306 00
6	Claw coupling		1	-
7	Seal		1	9000 0000 00
8(9-10)	Claw coupling, complete	US-universal $\frac{3}{4}$ "	1	9001 0005 06
9	Claw coupling		1	-
10	Seal		1	9001 0005 15

Breaker and hammer AIR-OIL

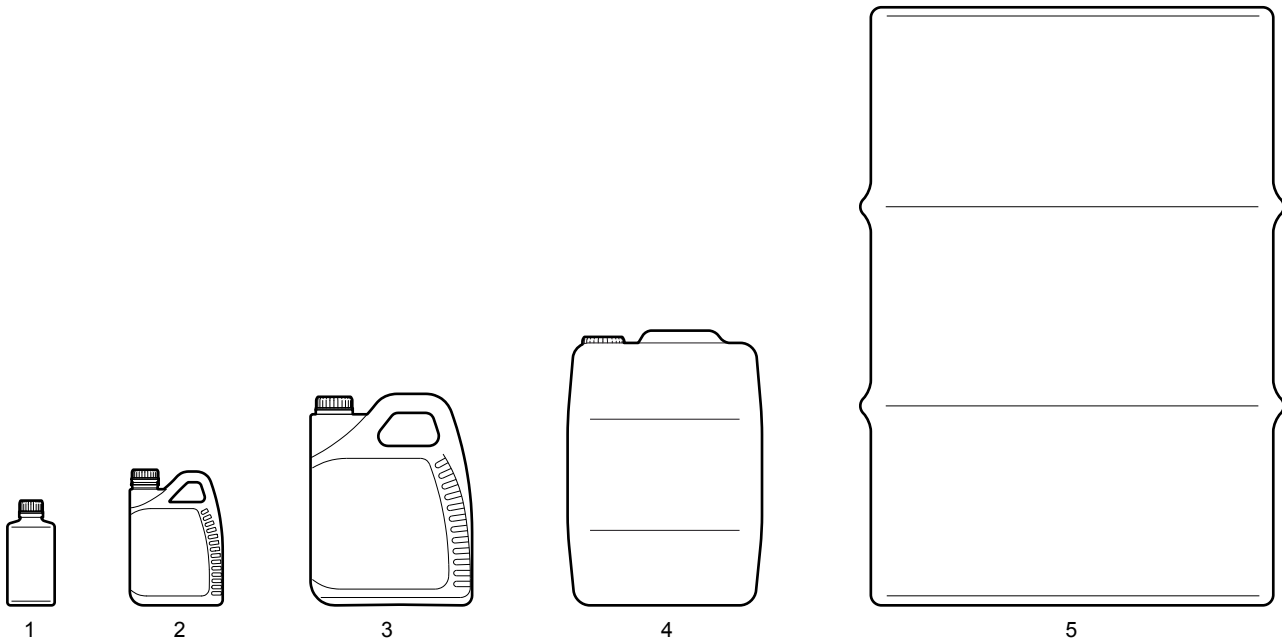

No.	Description	Remark	Quantity	Part number
1	Breaker and hammer AIR-OIL	0.2 l (0.040 gallon)	1	8099 0202 40
2	Breaker and hammer AIR-OIL	1 l (0.22 gallon)	1	8099 0202 36
3	Breaker and hammer AIR-OIL	5 l (1.1 gallon)	1	8099 0202 02
4	Breaker and hammer AIR-OIL	20 l (4.4 gallon)	1	8099 0202 15
5	Breaker and hammer AIR-OIL	208 l Drum (46 gallon)	1	8099 0202 28

Shank gauge

Description	Remark	Quantity	Part number
Gauge, hexagon 28	28 mm (1 $\frac{1}{8}$ "	1	3310 1509 28
Gauge, hexagon 32	32 mm (1 $\frac{1}{4}$ "	1	3310 1509 32



Unauthorized use or copying of all or part of the contents is prohibited. This specifically applies to trademarks, model designations, parts numbers and drawings.

© 2009 Atlas Copco Construction Tools AB | No. 9800 0852 01 | 2009-03-31

www.atlascopco.com